

Please check the examination details below before entering your candidate information

Candidate surname

Other names

Pearson Edexcel
International
Advanced Level

Centre Number

--	--	--	--	--

Candidate Number

--	--	--	--	--

Monday 1 June 2020

Afternoon (Time: 1 hour 45 minutes)

Paper Reference **WPH15/01**

Physics

International Advanced Level

**Unit 5: Thermodynamics, Radiation, Oscillations
and Cosmology**

You must have:

Scientific calculator, ruler

Total Marks

Instructions

- Use **black** ink or **black** ball-point pen.
- **Fill in the boxes** at the top of this page with your name, centre number and candidate number.
- Answer **all** questions.
- Answer the questions in the spaces provided – *there may be more space than you need.*
- **Show all your working out in calculations and include units where appropriate.**

Information

- The total mark for this paper is 90.
- The marks for **each** question are shown in brackets – *use this as a guide as to how much time to spend on each question.*
- In questions marked with an asterisk (*), marks will be awarded for your ability to structure your answer logically showing how the points that you make are related or follow on from each other where appropriate.
- The list of data, formulae and relationships is printed at the end of this booklet.

Advice

- Read each question carefully before you start to answer it.
- Try to answer every question.
- Check your answers if you have time at the end.

Turn over ►

P65750A

©2020 Pearson Education Ltd.

1/1/1/1/1/1



Pearson

SECTION A

Answer ALL questions.

For questions 1–10, in Section A, select one answer from A to D and put a cross in the box . If you change your mind, put a line through the box and then mark your new answer with a cross .

- 1 A radiation detector is placed near a radioactive source and measures the count rate from the source. Different absorbers are placed between the detector and the source. The results are shown in the table.

Absorber	Corrected count rate/s ⁻¹
None	850
Paper	850
Aluminium foil	150
Lead sheet	20

Which of the following is emitted by the source?

- A α -radiation only
- B β -radiation only
- C α -radiation and β -radiation
- D β -radiation and γ -radiation

(Total for Question 1 = 1 mark)

DO NOT WRITE IN THIS AREA

DO NOT WRITE IN THIS AREA

DO NOT WRITE IN THIS AREA



- 2 The graph shows how the binding energy per nucleon varies with nucleon number.

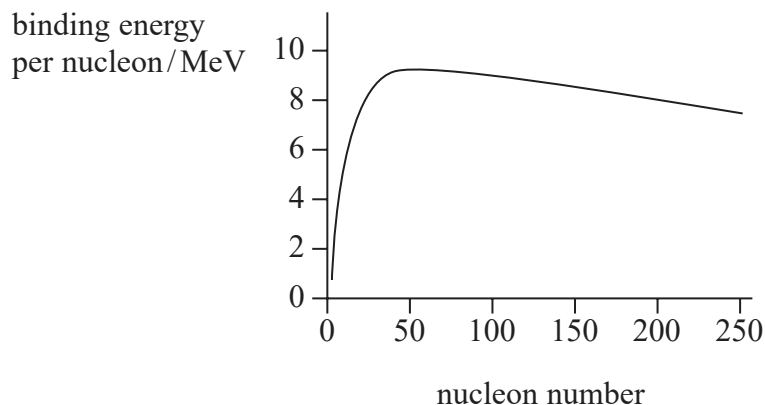

Which of the following conclusions is supported by this graph?

- A The total energy released is greatest when two low mass nuclei fuse.
- B The total energy absorbed is greatest when two low mass nuclei fuse.
- C The total energy released is greatest when a massive nucleus undergoes fission.
- D The total energy absorbed is greatest when a massive nucleus undergoes fission.

(Total for Question 2 = 1 mark)

- 3 A closed container holds a mixture of two gases at a constant temperature. Each molecule of gas X has a mass four times that of each molecule of gas Y.

What is the ratio $\frac{\text{r.m.s. velocity of molecules in gas X}}{\text{r.m.s. velocity of molecules in gas Y}}$?

- A $\frac{1}{4}$
- B $\frac{1}{2}$
- C 2
- D 4

(Total for Question 3 = 1 mark)



- 4 A negative temperature coefficient thermistor and a resistor are connected as shown.

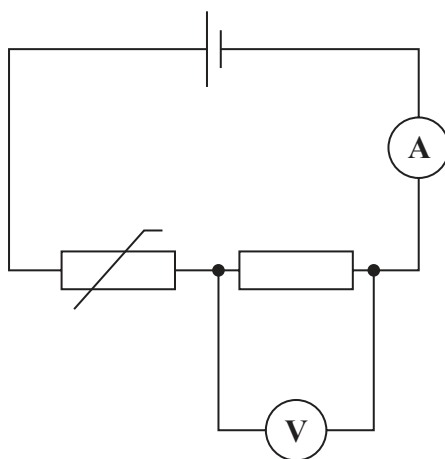

The temperature of the thermistor decreases.

Select the row of the table that shows how the readings on the meters change.

	Ammeter	Voltmeter
<input type="checkbox"/> A	decreases	decreases
<input type="checkbox"/> B	decreases	increases
<input type="checkbox"/> C	increases	decreases
<input type="checkbox"/> D	increases	increases

(Total for Question 4 = 1 mark)

- 5 A simple pendulum takes 1.00 s to swing from one extreme position to the other.

Which of the following expressions gives the length of the pendulum?

- A $\frac{(1.00)^2 - 9.81}{4\pi^2}$
- B $\frac{(2.00)^2 - 9.81}{4\pi^2}$
- C $\frac{4\pi^2}{(1.00)^2 - 9.81}$
- D $\frac{4\pi^2}{(2.00)^2 - 9.81}$

(Total for Question 5 = 1 mark)



Questions 6 and 7 both relate to an experiment carried out by a student to investigate the absorption of gamma radiation by lead.

The student used a GM-tube to measure the background count for 10 minutes. She then used the apparatus below to measure the count for 2 minutes for different thicknesses of lead.

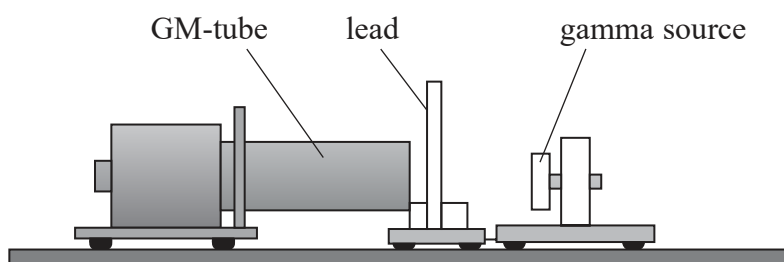

6 To correct the readings for the effect of background radiation she should

- A add the background count to each count.
- B add the background count rate to each count rate.
- C subtract the background count from each count.
- D subtract the background count rate from each count rate.

(Total for Question 6 = 1 mark)

7 The student discovered that a thickness of 1.0 cm of lead reduced the corrected count rate to 50% of its initial value with no lead.

Which of the following statements is correct?

- A A thickness of 0.5 cm would reduce the corrected count rate to 75% of its initial value.
- B A thickness of 0.5 cm would reduce the corrected count rate to 25% of its initial value.
- C A thickness of 2.0 cm would reduce the corrected count rate to 25% of its initial value.
- D A thickness of 2.0 cm would reduce the corrected count rate to zero.

(Total for Question 7 = 1 mark)



- 8 A solid is heated and it melts at a constant temperature.

Which row of the table shows how the kinetic energy and the potential energy of the molecules change as the solid melts?

	Molecular kinetic energy	Molecular potential energy
<input type="checkbox"/> A	increases	stays the same
<input type="checkbox"/> B	increases	increases
<input type="checkbox"/> C	stays the same	increases
<input type="checkbox"/> D	stays the same	stays the same

(Total for Question 8 = 1 mark)

- 9 A student hangs a mass from the end of a spring and sets the mass into vertical oscillation. The period of oscillation of the mass is T .

The student then hangs the same mass from a second spring, with a spring constant four times that of the first spring.

What is the period of oscillation of the mass on the second spring?

- A $T/4$
 B $T/2$
 C $2T$
 D $4T$

(Total for Question 9 = 1 mark)

- 10 Forcing a system into oscillation may result in resonance. For resonance to occur the oscillating system must be driven at its

- A natural frequency.
 B normal frequency.
 C optimum frequency.
 D damping frequency.

(Total for Question 10 = 1 mark)

TOTAL FOR SECTION A = 10 MARKS



SECTION B

Answer ALL questions in the spaces provided.

- 11** Electrostatic forces and gravitational forces can both be modelled by the idea of a field.
Give one similarity and one difference between electric fields and gravitational fields.

Similarity.....

.....

.....

Difference.....

.....

.....

(Total for Question 11 = 2 marks)

DO NOT WRITE IN THIS AREA

DO NOT WRITE IN THIS AREA

DO NOT WRITE IN THIS AREA



12 A massive planet orbits the red dwarf star Gliese 876. The planet was discovered after wavelength shifts in spectral lines were seen in the light received from the star.

(a) Explain how a massive planet orbiting a star can cause a change in the wavelength of light received from the star.

(3)

.....

.....

.....

.....

.....

.....

(b) The maximum shift in a spectral line of wavelength 4.35×10^{-7} m in the light received from Gliese 876 is 3.19×10^{-13} m.

Calculate the maximum velocity of Gliese 876 away from the Earth.

(2)

.....

.....

.....

Maximum velocity =

(Total for Question 12 = 5 marks)



DO NOT WRITE IN THIS AREA

DO NOT WRITE IN THIS AREA

DO NOT WRITE IN THIS AREA

13 Scientists have been working to achieve a practical nuclear fusion reactor for more than 70 years. So far, this has been with only limited success.

Explain the difficulties involved with fusion as a viable source of power on Earth.

You should include reference to the conditions necessary for fusion to occur.

.....

.....

.....

.....

.....

.....

.....

.....

.....

.....

.....

.....

.....

.....

.....

.....

.....

.....

.....

.....

.....

.....

.....

(Total for Question 13 = 4 marks)



14 The mean intensity of solar radiation arriving at the Earth is 1.37 kW m^{-2} .

(a) The distance of the Earth from the Sun is $1.50 \times 10^{11} \text{ m}$.

Show that the luminosity of the Sun is about $4 \times 10^{26} \text{ W}$.

(2)

.....

.....

.....

.....

.....

(b) The energy radiated from the Sun results in a decrease in the mass of the Sun.

Calculate the decrease in the mass of the Sun due to this radiation over a period of 1 year.

1 year = $3.15 \times 10^7 \text{ s}$

(2)

.....

.....

.....

.....

Decrease in mass =

(Total for Question 14 = 4 marks)



DO NOT WRITE IN THIS AREA

DO NOT WRITE IN THIS AREA

DO NOT WRITE IN THIS AREA

BLANK PAGE



P 6 5 7 5 0 A 0 1 1 3 6

15 The graph shows how the gravitational field strength g of the Earth varies with distance r from the centre of the Earth.

r is given in multiples of the radius R_E of the Earth.

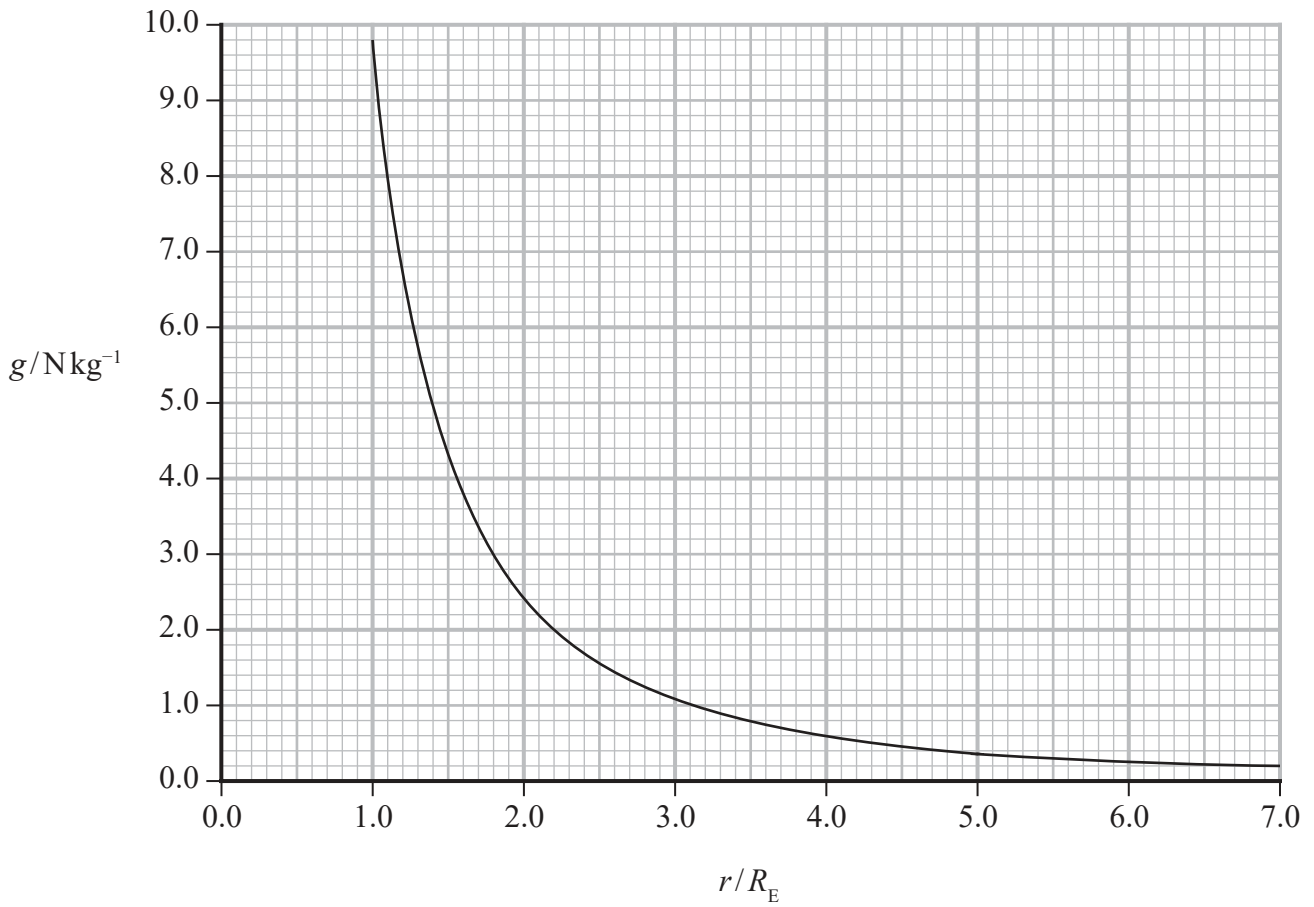

(a) Show that g obeys an inverse square law.

(3)

.....

.....

.....

.....

.....

.....

.....

.....

DO NOT WRITE IN THIS AREA

DO NOT WRITE IN THIS AREA

DO NOT WRITE IN THIS AREA



(b) A satellite is launched from the surface of the Earth into an orbit a height $5R_E$ above the surface of the Earth.

- (i) The change in gravitational potential energy ΔE_{grav} of a mass m when it experiences a vertical displacement Δh can be calculated using the expression

$$\Delta E_{\text{grav}} = mg\Delta h$$

State why this expression cannot be used to calculate the change in the gravitational potential energy of the satellite.

(1)

- (ii) Calculate the change in gravitational potential energy of the satellite.

mass of the Earth = 6.0×10^{24} kg

$R_E = 6.4 \times 10^6$ m

mass of satellite = 3.5×10^3 kg

(3)

Change in gravitational potential energy =

(Total for Question 15 = 7 marks)



16 Alnilam and Mintaka are stars in the constellation Orion.

The table gives some information about these stars.

Star	Surface temperature/K	Luminosity/ L_{Sun}	Distance from the Earth/m
Alnilam	2.75×10^4	5.37×10^5	1.90×10^{19}
Mintaka	3.00×10^4	9.00×10^4	8.70×10^{18}

$$L_{\text{Sun}} = 3.85 \times 10^{26} \text{ W}$$

(a) State where these stars would be located on a Hertzsprung-Russell diagram.

(1)

(b) Calculate the wavelength at which peak radiation power occurs for Mintaka.

(2)

Wavelength =

(c) Calculate the radius of Alnilam.

(2)

Radius of Alnilam =



(d) Deduce which of these stars gives the lower intensity of radiation at the Earth.

(3)

DO NOT WRITE IN THIS AREA

DO NOT WRITE IN THIS AREA

DO NOT WRITE IN THIS AREA

DO NOT WRITE IN THIS AREA

DO NOT WRITE IN THIS AREA

DO NOT WRITE IN THIS AREA

DO NOT WRITE IN THIS AREA

DO NOT WRITE IN THIS AREA

DO NOT WRITE IN THIS AREA

DO NOT WRITE IN THIS AREA

DO NOT WRITE IN THIS AREA

(Total for Question 16 = 8 marks)



18 Oganesson (Og) can be produced by firing calcium (Ca) ions at a target of californium (Cf) atoms. Oganesson and a number of neutrons are produced in the nuclear reaction.

(a) Complete the equation for the reaction

(1)

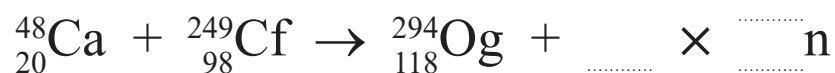

(b) The calcium ions were accelerated to an energy of 245 MeV.

(i) State how ions of this energy could be produced.

(1)

(ii) It is claimed that calcium ions with an energy of 245 MeV are travelling at relativistic speeds.

Assess the validity of this claim.

mass of calcium ion = 47.95 u

(5)



DO NOT WRITE IN THIS AREA

DO NOT WRITE IN THIS AREA

DO NOT WRITE IN THIS AREA

(c) The isotope Og-294 is extremely unstable and decays via alpha decay.

After 2.5 ms, a sample contains 500 atoms of Og-294.

Calculate the original number of Og-294 atoms in the sample.

half-life of Og-294 = 0.89 ms

(3)

.....

.....

.....

.....

.....

.....

.....

.....

Original number of atoms =

(d) Explain a precaution necessary when handling a sample of an alpha emitting isotope.

(2)

.....

.....

.....

.....

.....

.....

.....

.....

(Total for Question 18 = 12 marks)



19 Microwave ovens use microwave radiation at a frequency of 2.45 GHz to cook food. The absorption of microwave energy by water in the food causes a heating effect.

- (a) The graph shows how the energy absorbed by a water molecule depends on the frequency of the radiation.

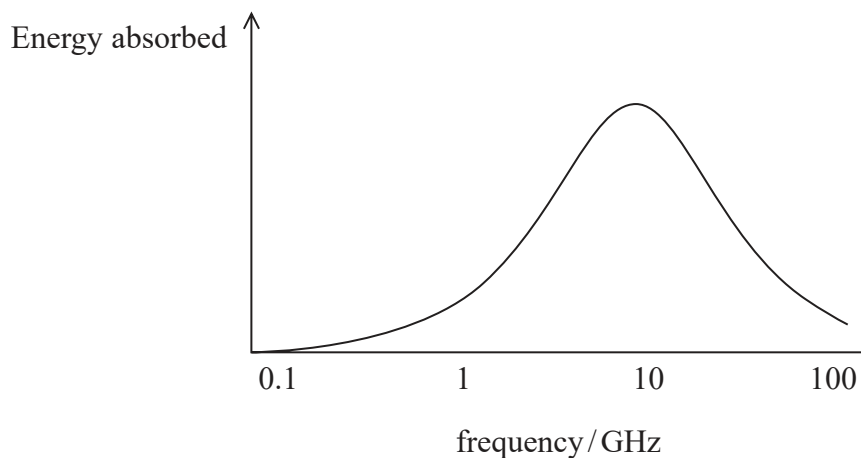

A website suggests that water molecules absorb energy because the microwaves produced by the oven cause the water molecules to resonate.

Comment on this suggestion.

(2)

.....

.....

.....

.....

- (b) The microwave radiation causes the water molecules to rotate.

(i) Explain how this cooks the food.

(3)

.....

.....

.....

.....

.....



(ii) Suggest why the transfer of energy from the microwaves may be less efficient for ice than for liquid water.

(2)

.....

.....

.....

.....

(c) 325 g of water at 25.0°C is heated at full power in a microwave oven. After 225 s the temperature of the water is 85.0°C.

power of microwave oven = 650 W

specific heat capacity of water = 4190 J kg⁻¹ K⁻¹

(i) The manufacturer claims that the microwave oven has an efficiency of 90%.

Assess the validity of this claim.

(3)

.....

.....

.....

.....

.....

.....

.....

.....

DO NOT WRITE IN THIS AREA

DO NOT WRITE IN THIS AREA

DO NOT WRITE IN THIS AREA



- (ii) The 325 g of hot water at 85.0 °C is poured into a polystyrene beaker containing 62.5 g of ice at 0.0 °C.

Calculate the final temperature of the mixture of water and melted ice.

latent heat of fusion of ice = $3.33 \times 10^5 \text{ J kg}^{-1}$

(4)

.....

.....

.....

.....

.....

.....

.....

.....

Final temperature of mixture =

(Total for Question 19 = 14 marks)

DO NOT WRITE IN THIS AREA

DO NOT WRITE IN THIS AREA

DO NOT WRITE IN THIS AREA



DO NOT WRITE IN THIS AREA

DO NOT WRITE IN THIS AREA

DO NOT WRITE IN THIS AREA

BLANK PAGE



P 6 5 7 5 0 A 0 2 3 3 6

- 20 A mass of 250 g is hung from a spring as shown. The spring extends by 16.5 cm when the mass is added to the spring.

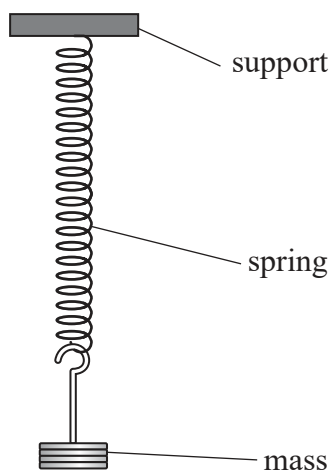

The mass is then displaced a further 3.5 cm vertically downwards and released. The mass oscillates with simple harmonic motion.

- (a) State the conditions for a mass to undergo simple harmonic motion.

(2)

.....

.....

.....

.....

- (b) Calculate the maximum kinetic energy of the oscillating mass.

(5)

.....

.....

.....

.....

.....

.....

.....

.....

Maximum kinetic energy =



DO NOT WRITE IN THIS AREA

DO NOT WRITE IN THIS AREA

DO NOT WRITE IN THIS AREA

(c) The graph shows how the displacement of the oscillating mass varies over two cycles.

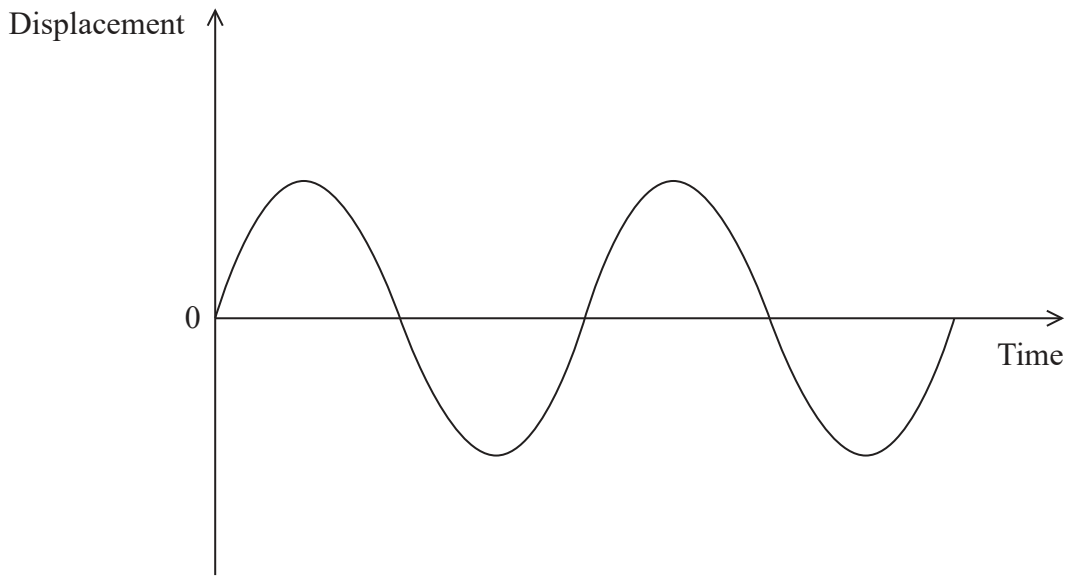

Add to the graph to show how the kinetic energy of the mass varies over the same time interval.

(2)



(d) The mass is submerged in water as shown.

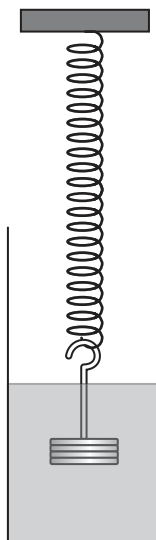

The mass is set into oscillation as before.

Explain how the water would affect the amplitude of oscillation of the mass.

(3)

.....

.....

.....

.....

.....

.....

.....

.....

(Total for Question 20 = 12 marks)

TOTAL FOR SECTION B = 80 MARKS
TOTAL FOR PAPER = 90 MARKS



List of data, formulae and relationships

Acceleration of free fall	$g = 9.81 \text{ m s}^{-2}$	(close to Earth's surface)
Boltzmann constant	$k = 1.38 \times 10^{-23} \text{ J K}^{-1}$	
Coulomb's law constant	$k = 1/4\pi\epsilon_0$ $= 8.99 \times 10^9 \text{ N m}^2 \text{ C}^{-2}$	
Electron charge	$e = -1.60 \times 10^{-19} \text{ C}$	
Electron mass	$m_e = 9.11 \times 10^{-31} \text{ kg}$	
Electronvolt	$1 \text{ eV} = 1.60 \times 10^{-19} \text{ J}$	
Gravitational constant	$G = 6.67 \times 10^{-11} \text{ N m}^2 \text{ kg}^{-2}$	
Gravitational field strength	$g = 9.81 \text{ N kg}^{-1}$	(close to Earth's surface)
Permittivity of free space	$\epsilon_0 = 8.85 \times 10^{-12} \text{ F m}^{-1}$	
Planck constant	$h = 6.63 \times 10^{-34} \text{ J s}$	
Proton mass	$m_p = 1.67 \times 10^{-27} \text{ kg}$	
Speed of light in a vacuum	$c = 3.00 \times 10^8 \text{ m s}^{-1}$	
Stefan-Boltzmann constant	$\sigma = 5.67 \times 10^{-8} \text{ W m}^{-2} \text{ K}^{-4}$	
Unified atomic mass unit	$u = 1.66 \times 10^{-27} \text{ kg}$	

Unit 1

Mechanics

Kinematic equations of motion

$$s = \frac{(u + v)t}{2}$$

$$v = u + at$$

$$s = ut + \frac{1}{2}at^2$$

$$v^2 = u^2 + 2as$$

Forces

$$\Sigma F = ma$$

$$g = \frac{F}{m}$$

$$W = mg$$

Momentum

$$p = mv$$

Moment of force

$$\text{moment} = Fx$$

Work and energy

$$\Delta W = F\Delta s$$

$$E_k = \frac{1}{2}mv^2$$

$$\Delta E_{\text{grav}} = mg\Delta h$$

Power

$$P = \frac{E}{t}$$

$$P = \frac{W}{t}$$

Efficiency

$$\text{efficiency} = \frac{\text{useful energy output}}{\text{total energy input}}$$

$$\text{efficiency} = \frac{\text{useful power output}}{\text{total power input}}$$



Materials

Density $\rho = \frac{m}{V}$

Stokes' law $F = 6\pi\eta rv$

Hooke's law $\Delta F = k\Delta x$

Elastic strain energy $\Delta E_{\text{el}} = \frac{1}{2} F\Delta x$

Young modulus $E = \frac{\sigma}{\varepsilon}$ where

Stress $\sigma = \frac{F}{A}$

Strain $\varepsilon = \frac{\Delta x}{x}$

DO NOT WRITE IN THIS AREA

DO NOT WRITE IN THIS AREA

DO NOT WRITE IN THIS AREA



Unit 2

Waves

Wave speed	$v = f\lambda$
Speed of a transverse wave on a string	$v = \sqrt{\frac{T}{\mu}}$
Intensity of radiation	$I = \frac{P}{A}$
Refractive index	$n_1 \sin \theta_1 = n_2 \sin \theta_2$ $n = \frac{c}{v}$
Critical angle	$\sin C = \frac{1}{n}$
Diffraction grating	$n\lambda = d \sin \theta$

Electricity

Potential difference	$V = \frac{W}{Q}$
Resistance	$R = \frac{V}{I}$
Electrical power, energy and efficiency	$P = VI$ $P = I^2R$ $P = \frac{V^2}{R}$ $W = VI t$
Resistivity	$R = \frac{\rho l}{A}$
Current	$I = \frac{\Delta Q}{\Delta t}$ $I = nqvA$
Resistors in series	$R = R_1 + R_2 + R_3$
Resistors in parallel	$\frac{1}{R} = \frac{1}{R_1} + \frac{1}{R_2} + \frac{1}{R_3}$

Particle nature of light

Photon model	$E = hf$
Einstein's photoelectric equation	$hf = \phi + \frac{1}{2} mv_{\max}^2$
de Broglie wavelength	$\lambda = \frac{h}{p}$



Unit 4*Mechanics*

Impulse

$$F\Delta t = \Delta p$$

Kinetic Energy of a non-relativistic particle

$$E_k = \frac{p^2}{2m}$$

motion in a circle

$$v = \omega r$$

$$T = \frac{2\pi}{\omega}$$

$$a = \frac{v^2}{r}$$

Centripetal force

$$F = ma = \frac{mv^2}{r}$$

$$F = m\omega^2 r$$

Electric and magnetic fields

Electric Field

$$E = \frac{F}{Q}$$

Coulomb's Law

$$F = \frac{Q_1 Q_2}{4\pi\epsilon_0 r^2}$$

$$E = \frac{Q}{4\pi\epsilon_0 r^2}$$

$$E = \frac{V}{d}$$

Electrical Potential

$$V = \frac{Q}{4\pi\epsilon_0 r}$$

Capacitance

$$C = \frac{Q}{V}$$

Energy Stored in capacitor

$$W = \frac{1}{2} QV$$

$$W = \frac{1}{2} CV^2$$

$$W = \frac{1}{2} \frac{Q^2}{C}$$

Capacitor discharge

$$Q = Q_0 e^{-t/RC}$$



Resistor capacitor discharge

$$I = I_0 e^{-t/RC}$$

$$V = V_0 e^{-t/RC}$$

$$\ln Q = \ln Q_0 - \frac{t}{RC}$$

$$\ln I = \ln I_0 - \frac{t}{RC}$$

$$\ln V = \ln V_0 - \frac{t}{RC}$$

In a magnetic field

$$F = Bqv \sin\theta$$

$$F = BIl \sin\theta$$

Faraday and Lenz's law

$$E = \frac{-d(N\phi)}{dt}$$

Nuclear and particle physics

In a magnetic field

$$r = \frac{p}{BQ}$$

Mass-energy

$$\Delta E = c^2 \Delta m$$



Unit 5*Thermodynamics*

Heating

$$\Delta E = mc\Delta\theta$$

$$\Delta E = L\Delta m$$

Ideal gas equation

$$pV = NkT$$

Molecular kinetic theory

$$\frac{1}{2}m \langle c^2 \rangle = \frac{3}{2}kT$$

Nuclear decay

Mass-energy

$$\Delta E = c^2\Delta m$$

Radio-active decay

$$A = \lambda N$$

$$\frac{dN}{dt} = -\lambda N$$

$$\lambda = \frac{\ln 2}{t_{1/2}}$$

$$N = N_0 e^{-\lambda t}$$

$$A = A_0 e^{-\lambda t}$$

Oscillations

Simple harmonic motion

$$F = -kx$$

$$a = -\omega^2 x$$

$$x = A \cos \omega t$$

$$v = -A\omega \sin \omega t$$

$$a = -A\omega^2 \cos \omega t$$

$$T = \frac{1}{f} = \frac{2\pi}{\omega}$$

$$\omega = 2\pi f$$

Simple harmonic oscillator

$$T = 2\pi \sqrt{\frac{m}{k}}$$

$$T = 2\pi \sqrt{\frac{l}{g}}$$



Astrophysics and Cosmology

Gravitational field strength

$$g = F/m$$

Gravitational force

$$F = \frac{Gm_1m_2}{r^2}$$

Gravitational field

$$g = \frac{Gm}{r^2}$$

Gravitational potential

$$V_{grav} = \frac{-Gm}{r}$$

Stephan-Boltzman law

$$L = \sigma T^4 A$$

Wein's law

$$\lambda_{max} T = 2.898 \times 10^{-3} \text{ m K}$$

Intensity of radiation

$$I = \frac{L}{4\pi d^2}$$

Redshift of electromagnetic radiation

$$z = \frac{\Delta\lambda}{\lambda} \approx \frac{\Delta f}{f} \approx \frac{v}{c}$$

Cosmological expansion

$$v = H_0 d$$

DO NOT WRITE IN THIS AREA

DO NOT WRITE IN THIS AREA

DO NOT WRITE IN THIS AREA



DO NOT WRITE IN THIS AREA

DO NOT WRITE IN THIS AREA

DO NOT WRITE IN THIS AREA

BLANK PAGE



DO NOT WRITE IN THIS AREA

DO NOT WRITE IN THIS AREA

DO NOT WRITE IN THIS AREA

BLANK PAGE



DO NOT WRITE IN THIS AREA

DO NOT WRITE IN THIS AREA

DO NOT WRITE IN THIS AREA

BLANK PAGE

